

Date: _____
Revision: _____

Anti Dust Hopper Inquiry Form



Please fill out this form and reply with attached pictures of installation site, and material to help us ensure that we can provide you with the most accurate and efficient service possible.

If you find yourself with any questions, do not hesitate to reach out to our sales manager. We are ready and waiting to assist you with any queries you may have.

Hadi Alizadeh
H.alizadeh@dsdaco.com
+989127223263

We appreciate your cooperation and look forward to working with you.

Inquiry Form			
Company Information			
Company Name:	_____	Contact Person:	_____
Country:	_____	Email Address:	_____
City:	_____	Phone Number:	_____
Address:	_____	Website:	_____
Application Details			
Material:	_____	Rate - Q (kg/h):	_____
Particle Size (μ): Max 3000 μ	_____	H1 (cm):	_____
Humidity Range (%):	_____	H2 (cm):	_____

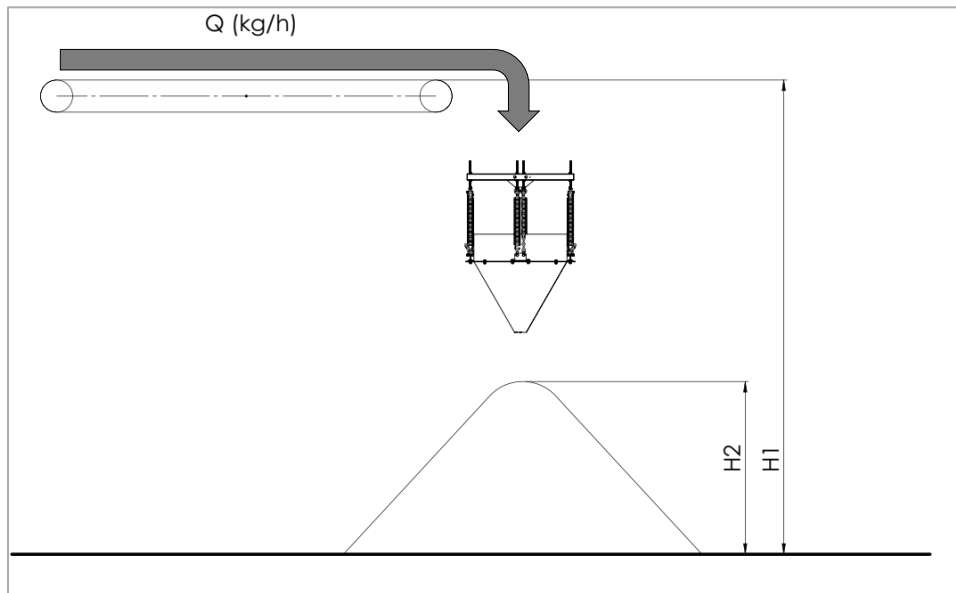

Durali System Design & Automation

Unit 4, No. 33, Sadeghi St., Azadi Ave., Tehran, Iran | www.dsdaco.com
p.(0098) 021-66059245 | f.(0098) 021-66059627 | info@dsdaco.com